

• General Description

The ZM120N04S combines trench MOSFET technology with a low resistance package to provide extremely low $R_{DS(ON)}$.

• Features

- Advance high cell density Trench technology
- Low $R_{DS(ON)}$ to minimize conductive loss
- Low Gate Charge for fast switching
- Low Thermal resistance

• Application

- POL application
- SMPS 2nd Synchronous Rectifier
- BLDC Motor driver

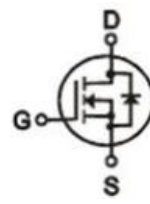
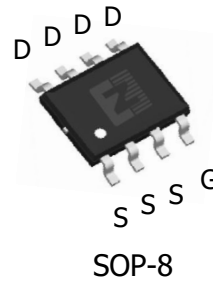
• Product Summary

 $V_{DS} = 40V$
 $R_{DS(ON)} = 12.5m\Omega$
 $I_D = 10A$

• Ordering Information:

Part NO.	ZM120N04S
Marking	ZM120N04
Packing Information	REEL TAPE
Basic ordering unit (pcs)	4000

• Absolute Maximum Ratings (T_C = 25°C)

Parameter	Symbol	Rating	Unit
Drain-Source Voltage	V_{DS}	40	V
Gate-Source Voltage	V_{GS}	±20	V
Continuous Drain Current ^②	$I_{D@TC=25^{\circ}C}$	10	A
	$I_{D@TC=75^{\circ}C}$	7.6	A
	$I_{D@TC=100^{\circ}C}$	6.3	A
Pulsed Drain Current ^①	I_{DM}	30	A
Total Power Dissipation ^②	$P_D@TC=25^{\circ}C$	3.1	W
Total Power Dissipation	$P_D@TA=25^{\circ}C$	0.69	W
Operating Junction Temperature	T_J	-55 to 150	°C
Storage Temperature	T_{STG}	-55 to 150	°C
Single Pulse Avalanche Energy@L=0.1mH	E_{AS}	125	mJ

•Thermal resistance

Parameter	Symbol	Min.	Typ.	Max.	Unit
Thermal resistance, junction - case ^②	R _{thJC}	-	-	40	°C/W
Thermal resistance, junction - ambient	R _{thJA}	-	-	180	°C/W
Soldering temperature, wavesoldering for 10s	T _{sold}	-	-	265	°C

•Electronic Characteristics

Parameter	Symbol	Condition	Min.	Typ	Max.	Unit
Drain-Source Breakdown Voltage	BV _{DSS}	V _{GS} = 0V, I _D = 250uA	40			V
Gate Threshold Voltage	V _{GS(TH)}	V _{GS} = V _{DS} , I _D = 250uA	1.2		2.5	V
Drain-Source Leakage Current	I _{DSS}	V _{DS} = 40V, V _{GS} = 0V			1.0	uA
Gate- Source Leakage Current	I _{GSS}	V _{GS} = ±20V, V _{DS} = 0V			±100	nA
Static Drain-source On Resistance	R _{DS(ON)}	V _{GS} = 10V, I _D = 10A		12.5	15	mΩ
		V _{GS} = 4.5V, I _D = 6A		18	21	mΩ
Forward Transconductance	g _{FS}	V _{DS} = 25V, I _D = 2A		20		s
Source-drain voltage	VSD	I _S = 10A			1.28	V

•Electronic Characteristics

Parameter	Symbol	Condition	Min.	Typ	Max.	Unit
Input capacitance	C _{iss}	f = 1MHz V _{DS} = 25V	-	2750	-	pF
Output capacitance	C _{oss}		-	185	-	
Reverse transfer capacitance	C _{rss}		-	135	-	

Gate Charge characteristics(T_a = 25°C)

Parameter	Symbol	Condition	Min.	Typ	Max.	Unit
Total gate charge	Q _g	V _{DD} = 30V	-	30	-	nC
Gate - Source charge	Q _{gs}	I _D = 6A	-	9	-	
Gate - Drain charge	Q _{gd}	V _{GS} = 10V	-	15	-	

Note: ① Pulse Test : Pulse width ≤ 300μs, Duty cycle ≤ 2% ;

② Device mounted on FR-4 substrate PC board, 2oz copper, with thermal bias to bottom layer 1inch square copper plate;

Fig.1 Gate-Charge Characteristics

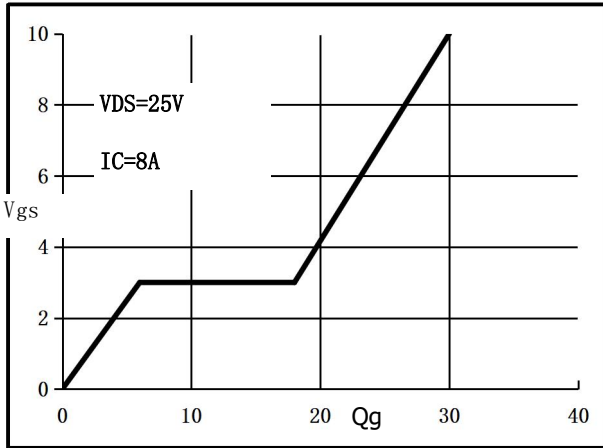

Fig.2 Capacitance Characteristics

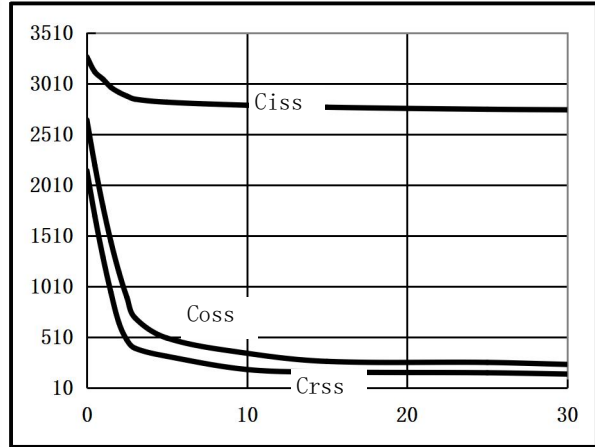

Fig.3 Power Dissipation Derating Curve

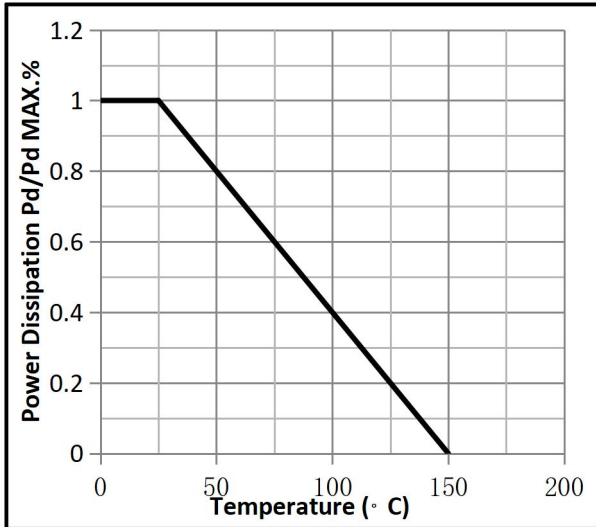

Fig.4 Typical output Characteristics

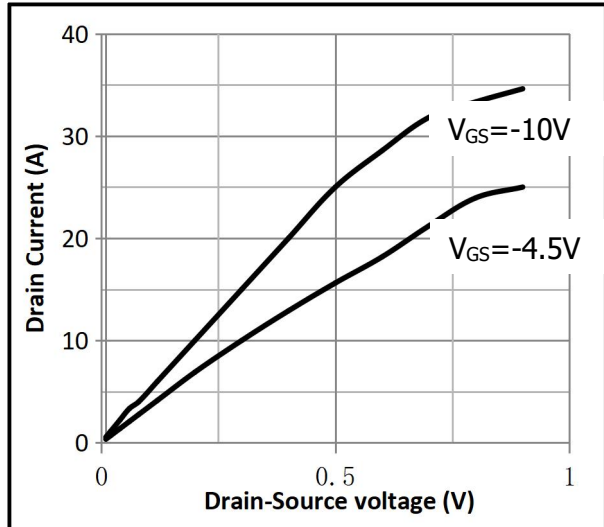

Fig.5 Threshold Voltage V.S Junction Temperature

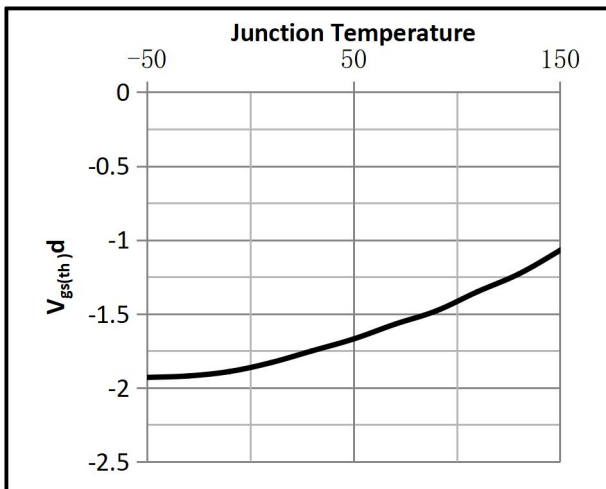

Fig.6 Resistance V.S Drain Current

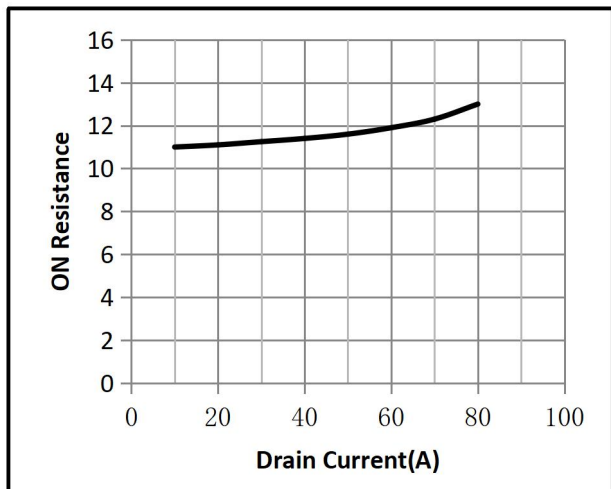

Fig.7 On-Resistance VS Gate Source Voltage

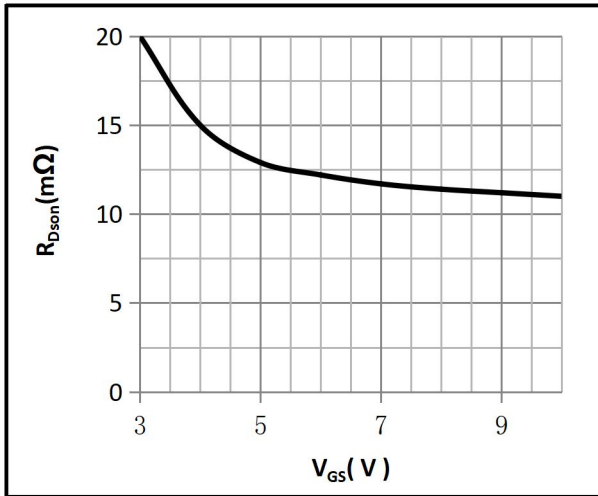

Fig.8 On-Resistance V.S Junction Temperature

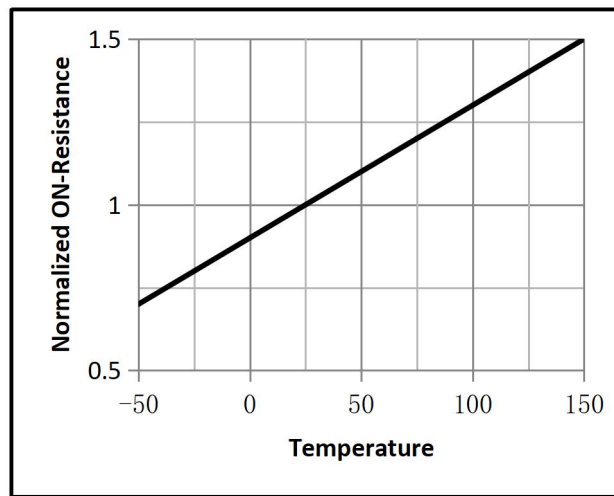

Fig.9 Switching Time Measurement Circuit

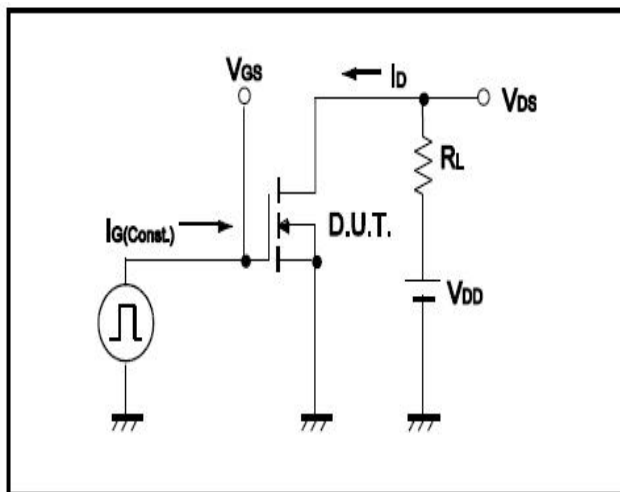

Fig.10 Gate Charge Waveform

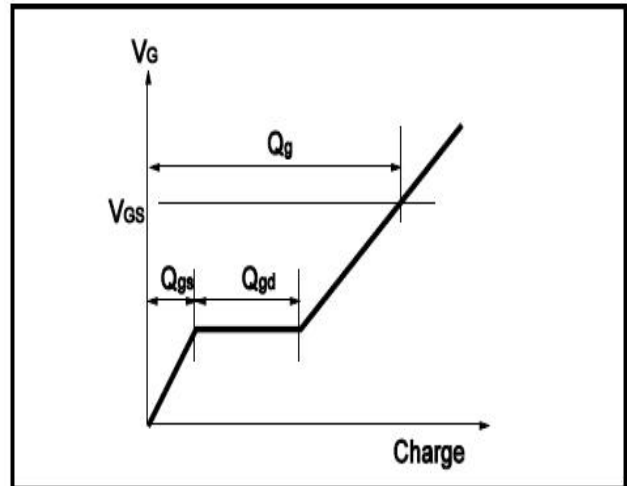

Fig.11 Switching Time Measurement Circuit

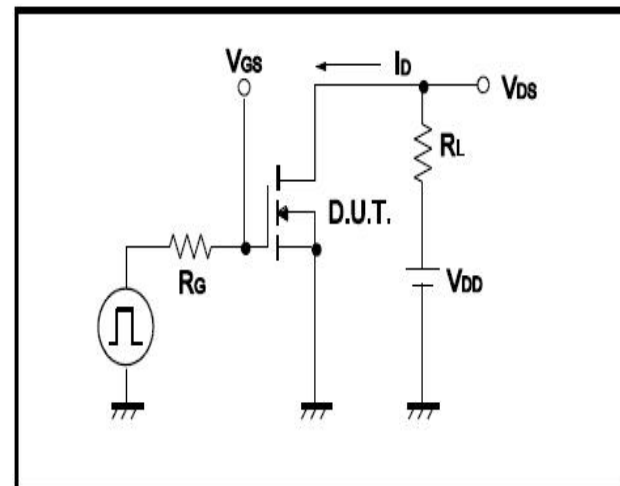
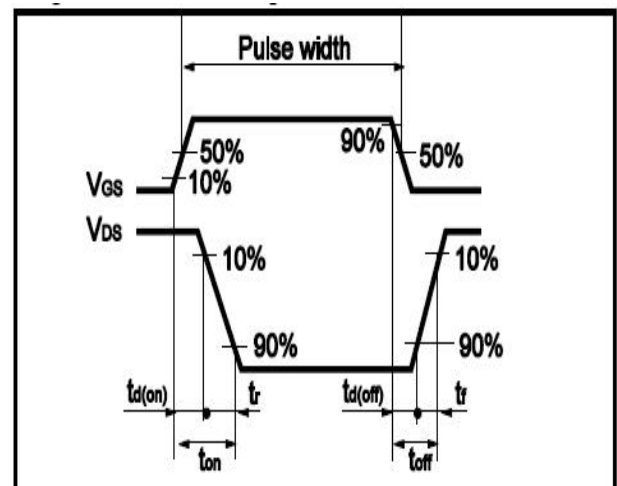

Fig.12 Gate Charge Waveform



•Dimensions(SOP8)

Unit: mm

SYMBOL	min	TYP	max	SYMBOL	min		max
A	4.80		5.00	C	1.30		1.50
A1	0.37		0.47	C1	0.55		0.75
A2		1.27		C2	0.55		0.65
A3		0.41		C3	0.05		0.20
B	5.80		6.20	C4	0.19	0.20	0.23
B1	3.80		4.00	D		1.05	
B2		5.00		D1	0.40		0.62

